

DIMENSIONS AND DATA

4 1/4 X 4 3/4 CORE - 2 COIL UNIT

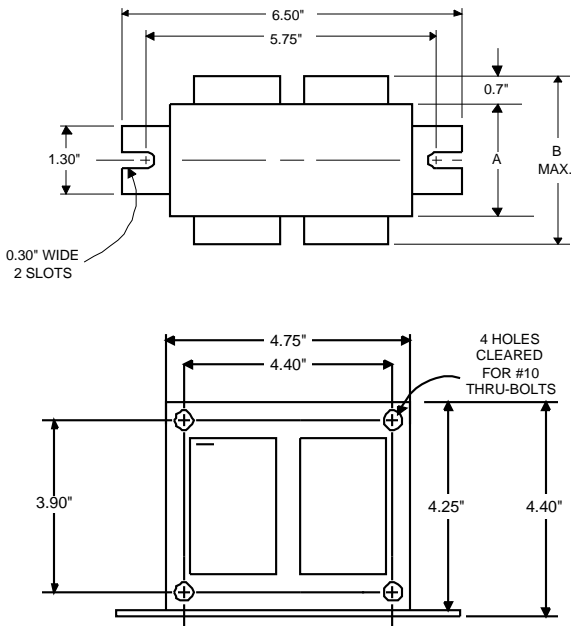

Capacitor: 7C175M30-R



Capacitance: 17.5
Dia/Oval Dim: 1.5
Height: 3.75
Temp Rating: 105°C

Ignitor: NA

This ballast does not require the use of an ignitor.

	120	208	240	277
INPUT VOLTS				
CIRCUIT TYPE	HX-HPF			
POWER FACTOR (min)	90%			
REGULATION				
Line Volts	±5%			
Lamp Watts	±10%			
LINE CURRENT (Amps)				
Operating.....	1.06	0.60	0.53	0.50
Open Circuit.....	4.10	2.30	2.00	1.75
Starting.....	1.15	0.65	0.60	0.52
UL TEMPERATURE RATINGS	H(180°C)			
Insulation Class	1029			
Coil Temperature Code	-20°F or -30°C	A	A	A
MIN. AMBIENT STARTING TEMP.	515			
NOM. OPEN CIRCUIT VOLTAGE				
INPUT VOLTAGE AT LAMP DROPOUT.....	65	110	120	140
INPUT WATTS				
RECOMMENDED FUSE (Amps).....	11	6	5	5
CORE and COIL				
Dimension (A)	3.25			
Dimension (B)	10			
Weight (lbs.)	12"			
Lead Lengths				
CAPACITOR REQUIREMENT				
Microfarads	17.5			
Volts (min.)	330			
Fault Current Withstand (amps)				
60 Hz TEST PROCEDURES (Refer to Philips Lighting Electronics N.A. TEST Procedure for HID Ballasts - Form High Potential Test (Volts)				
1 minute	2000			
2 seconds	2500			
460-565				
Open Circuit Voltage Test (Volts)				
Short-Circuit Current Test (Amps)	0.90-1.10			
Secondary Current				
Input Current.....	0.32	0.17	0.16	0.13
	0.48	0.26	0.24	0.20

Wiring Diagram:

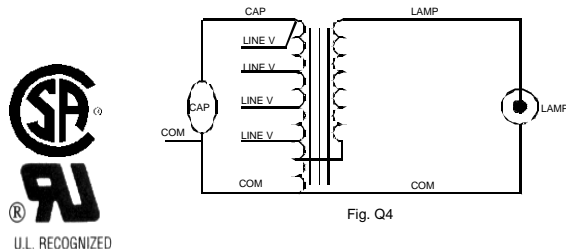

Typical Ordering Information

(please call Philips Lighting Electronics N.A. for suffix availability)

Order Suffix	Description
--------------	-------------

Data is based upon tests performed by Philips Lighting Electronics N.A. in a controlled environment and is representative of relative performance. Actual performance can vary depending on operating conditions. Specifications are subject to change without notice.

PHILIPS LIGHTING ELECTRONICS N.A.

10275 WEST HIGGINS ROAD · ROSEMONT, IL 60018

Tel: 800-322-2086 · Fax: 888-423-1882 · www.philips.com/advance

Customer Support/Technical Service: 800-372-3331 · OEM Support: 866-915-5886

Revised: 05/19/05